

VERTICAL DOORS, INC.

VerticalDoors.com

542 3Rd Street, Lake Elsinore, CA
Tel: 951.245.8669 Fax 951.273.1854



CORVETTE "C3" 68-82

Vertical Door Kit

U.S. PATENTS

#6,808,223; #6,845,547; #7,140,075; #7,059,655

PATENTS AGGRESSIVELY ENFORCED!





**PLEASE CAREFULLY READ ALL INSTRUCTIONS BEFORE
ATTEMPTING TO INSTALL THIS PRODUCT.**

**FOR QUESTIONS, PLEASE
CONTACT US AT (951) 245-1069**

THIS KIT INCLUDES:

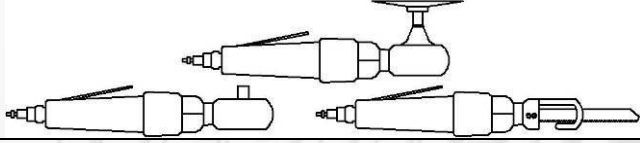
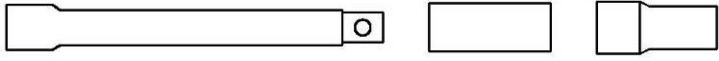
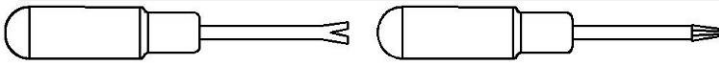
➤ RIGHT AND LEFT HINGE ASSEMBLY	➤ 2 XL SHOCKS 300 PSI
➤ 8 M8-1.25X30MM BOLTS WITH WASHERS	➤ 8 M8-1.25X40MM BOLTS WITH WASHERS

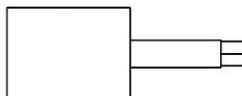
TOOLS REQUIRED FOR INSTALLATION:

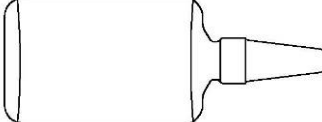
	➤ AIR RACHET, GRINDER AND CUTTER.
	➤ 7MM, 8MM, 10MM, 11MM, 13MM, SOCKETS AND EXTENSION.
	➤ FORK AND PHILLIP'S SCREW DRIVERS
	➤ SPACERS FOR THE DOOR GAP.
	➤ 3/16 ALLEN WRENCH
	➤ 1/4 & T15 TORX BIT
	➤ 9/16 WRENCH
	➤ LOCKTITE RED

OTHER TOOLS MAY BE NEEDED DEPENDING ON YOUR VEHICLE.



(Note: The pictures in the manual are for reference only they may not match your vehicle.)

Disconnect the battery.

Mark the factory location of the door using 2 inch painters tape on the door and the body.

Once you have part the factory location you will need to remove the door.



Remove the door panel. This will give you access to the bolts securing the door to the factory hinge.

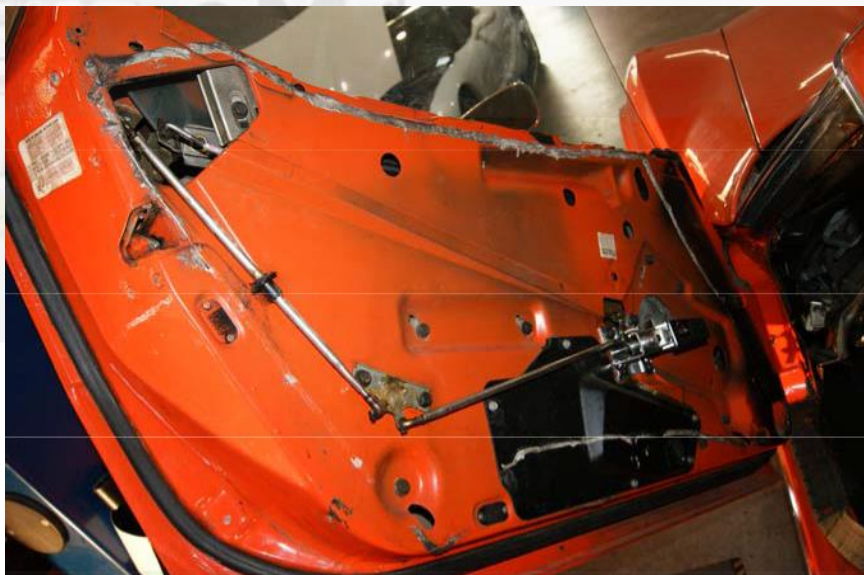

Remove the kick plate to gain access to the factory bolts. There are 4 in each hinge.

Note: You can't see the top bolts; you will have to use your hand to feel for them.



VERTICAL DOORS, INC.
VerticalDoors.com

To Install the new VDI Lambo Door kit you will have to use part of the factory hinge.



Separate the factory hinges into two halves by removing the original hinge pin (using a hammer and a punch) You will use the door half, set aside the body half.

Picture on the right shows the factory hinge installed on the new VDI Hinge after it has been cut.



You will need to trim one of the stock hinges on each side. The one with the Detent must be trimmed to match the other.

Install the factory hinge onto the new VDI Hinge using the original hinge pins and a hammer.

The picture on the right shows the stock hinges. The part that is circled (Detent) needs to be trimmed off to match the other hinge.



You will have to trim the very bottom of the drip rail as shown in the image on the right.

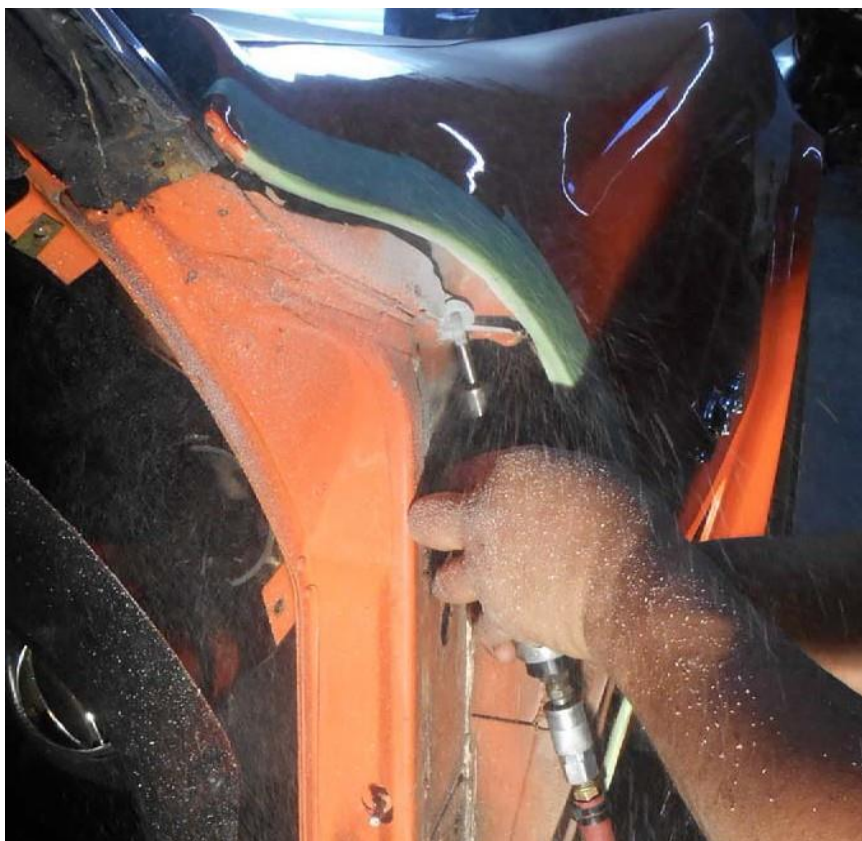

Measure from the edge of the door indentation to the edge of the apron as shown in the picture on the right. You will need about 3 inches of clearance.



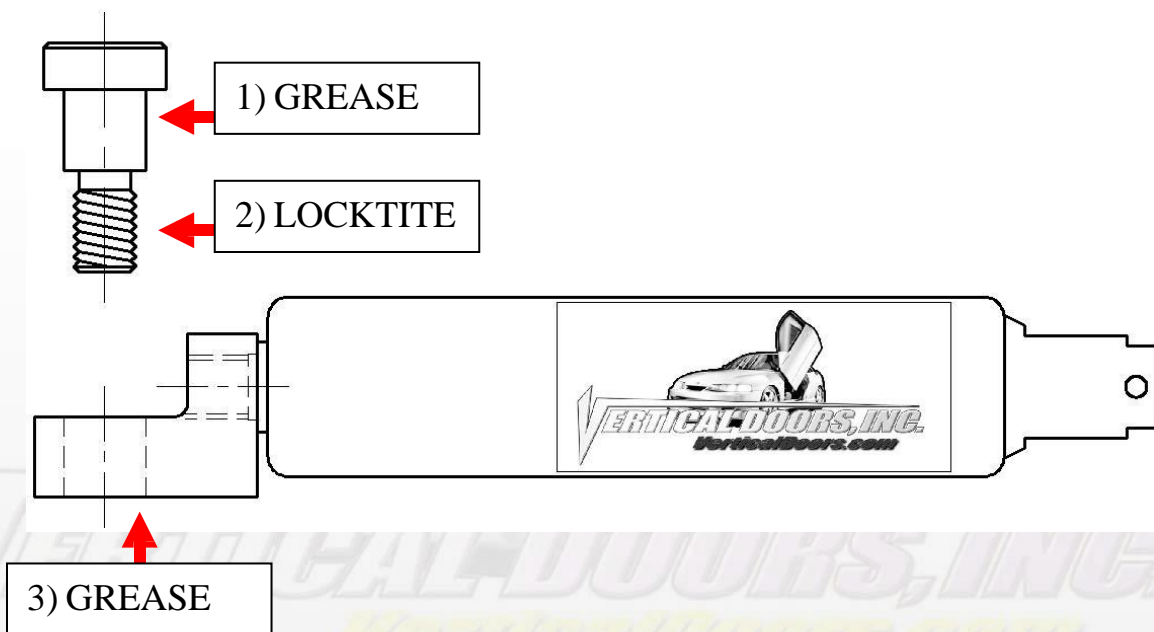

***IMPORTANT STEP: DO NOT SKIP THIS STEP. THIS STEP IS CRUCIAL IN YOUR INSTALLATION PROCESS, IF THIS STEP IS NOT COMPLETED WHEN INSTALLING THE VERTICAL DOOR KIT; ALL WARRANTIES ARE VOIDED, AND MAY CAUSE FUTURE PROBLEMS WITH YOUR VERTICAL DOOR SYSTEM.**

- 1ST, make sure you put grease on the body of shoulder bolt where the arrow is pointing.
- 2ND, make sure you put red Loctite, where the arrow is pointing, on thread of shoulder bolt.
- 3RD, make sure you put grease on the bottom side of the shock end.

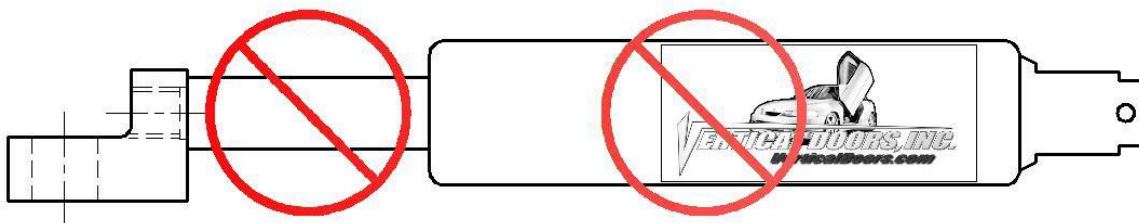

WARNING! THE USE OF ANY TYPE PLIERS, PAINT OR FOREIGN MATERIALS ON THE SHOCK'S BODY OR SHAFT WILL VOID THE WARRANTY.

You will also need to elongate the holes by about $\frac{1}{4}$ inch as shown in the image on the right.



Install the new VDI Hinge. Make sure to re-install any shims used with the original hinges.

The hinge should be about .5-.6 inches from the edge as shown in the image on the right.

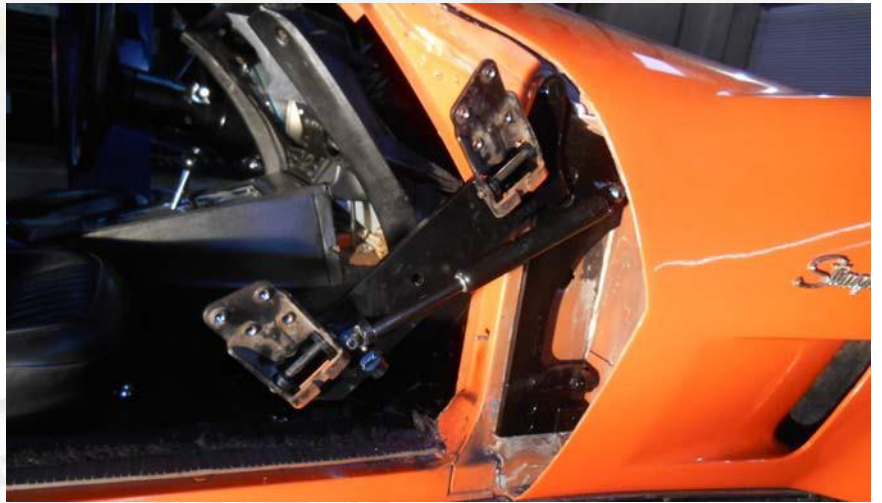

Tighten the bolts on the new VDI Hinge.



You will have to extend the factory wires about 6 inches.



Install the Door back on the car. You will need a helper for this step. Secure the bolts and test the door. You may have to adjust it by moving the adjustment points on the hinge or loosening the bolts and moving the hinge.

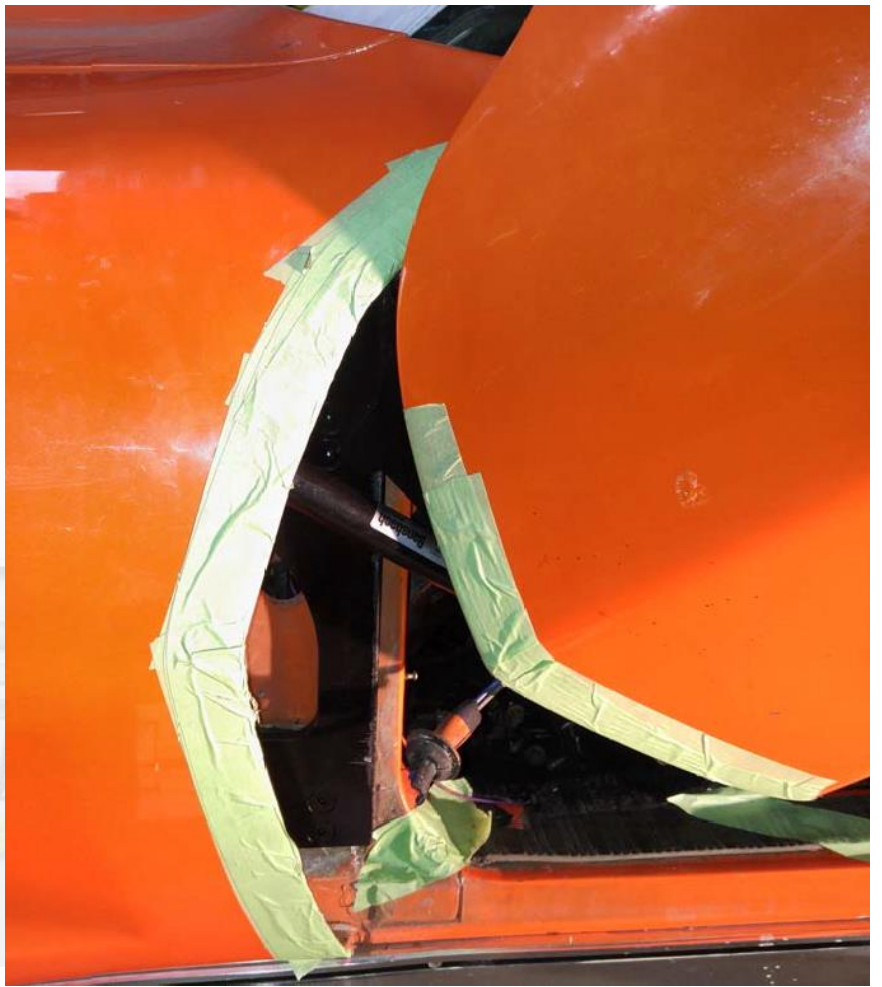

For the other side just follow the same steps.





**Thank you for your purchase of the
CORVETTE C3**

VERTICAL DOORS INC. SYSTEM





NOTE:

Vertical Doors Inc. assumes no responsibility for any damages caused by improper installation. The pictures on the manual are for reference only they may not match your vehicle.

